

# Type **TW17**

**WEH<sup>®</sup> Connector for pneumatic and hydraulic pressure and function testing**  
of components with female thread



General

**DESCRIPTION**



**Features**

- Connection in seconds
- No hand tightening required
- WEH® Jaw locking mechanism
- Modified clamping jaws for increased flow
- Ergonomic design
- High-grade materials
- Different actuations
- Automation possible
- Testing devices are eliminated

The WEH® TW17 Quick connector is designed for sealing standardized female thread applications. The higher the test pressure the tighter the WEH® Connector will clamp itself into the thread of the test piece and provides a pressure-tight connection in seconds. The front o-ring reliably seals the connection and no additional clamping devices are required. Time-consuming and expensive testing devices are eliminated.

Bores have been added as standard to the clamping jaws for body sizes 5 - 6 of the WEH® TW17 Connector to increase flow rates.

The WEH® TW17 Connector is available with different actuations:

TW17H - Manual actuation via lever

TW17V - Pneumatic actuation via valve head

TW17P - Pneumatic actuation for external manual, semi or fully automatic control systems

The actuation can be easily changed at any time by simply unscrewing the rear part of the connector and replacing it with the chosen actuation.



TW17 with bores for increased flow

Special versions, e.g. connectors in longer or shorter versions, as a plug or with hydraulic actuation etc. are possible (see special solutions).

**Application**

Quick connector for pneumatic and hydraulic pressure and function testing of components with female thread, e.g. engines, cylinders, pressure vessels, hoses, fixtures, etc.

**Note:** For using the WEH® Connectors with pneumatic actuation and clamping jaws in an automated system please observe the technical explanation on page 71 in catalog no. 35.

**TECHNICAL DATA**

Characteristics	Basic version
Max. allowable operating pressure PS	Vacuum up to 350 bar
Pilot pressure	6 - 12 bar compressed air
Pilot pressure port P1	G1/8" female thread
Pilot pressure port P2	G1/4" female thread
Temperature range	+5 °C up to +80 °C
Leak rate	1 x 10 <sup>-3</sup> mbar x l/s
Actuation	H = manual actuation via lever V = pneumatic actuation via valve head P = pneumatic actuation for external manual, semi or fully automatic control systems
Material	Corrosion resistant stainless steel, anodized aluminum
Sealing material	Front seal of NBR

Other designs on request

**Example of use:**



Ordering

**ORDERING** | WEH® TW17 Quick connector

approx. dimensions (mm)

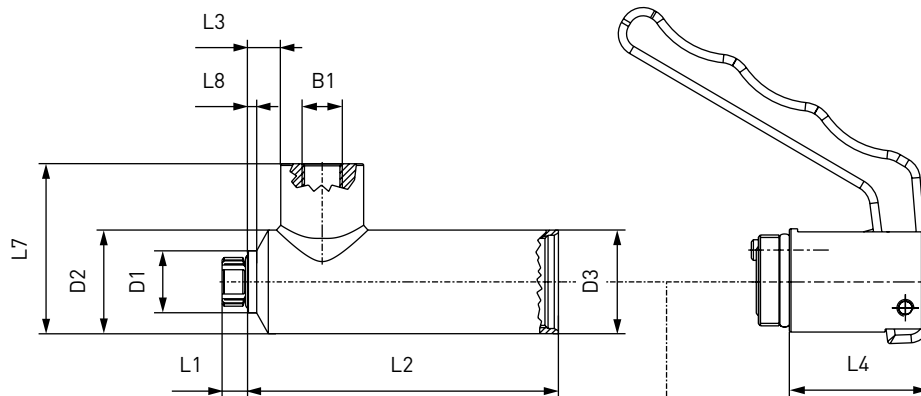

**H**  
Manually by depressing the lever.  
*Medium effort required.*

Body size 1 - 4

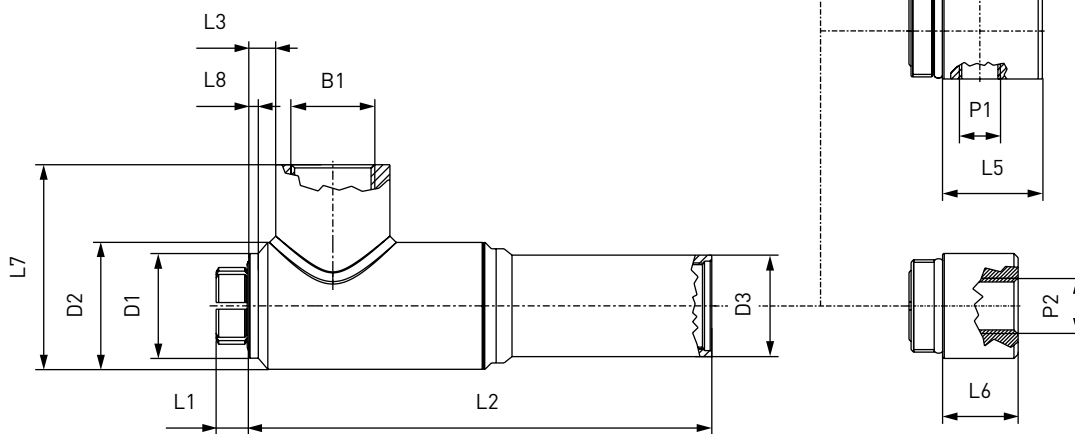

**V**  
Pneumatically by pressing the valve head.  
*Very little effort required.*

**P**  
Pneumatically for external manual, semi or fully automatic control systems

Body size 5 - 6

Body size	B1 (female thread)	D1	D1*	D2	D2*	D3	L1	L2	L3	L4	L5	L6	L7	L8	L8*
1	G1/8"	15.0	15.0	25.0	25.0	25.0	8.0	75.0	8.0	33.5	24.0	18.0	44.0	2.5	2.5
2	G1/4"	19.0	20.5	27.0	27.0	27.0	9.0	75.0	9.0	32.0	18.0	18.0	40.0	2.5	5.0
3	G3/8"	23.0	26.0	32.0	32.0	32.0	12.0	88.0	9.5	35.0	18.0	18.0	50.0	2.0	4.0
4	G1/2"	27.0	29.0	37.0	37.0	37.0	12.0	88.0	8.0	35.0	18.0	18.0	55.0	3.0	4.0
5	G3/4"	33.0	40.5	40.0	45.0	32.0	14.0	145.0	8.0	35.0	18.0	18.0	68.5	3.0	8.0
6	G1"	40.0	46.5	49.0	49.0	32.0	14.0	168.0	18.0	35.0	18.0	18.0	77.0	3.0	5.0

\* applies to SAE J1926

Ordering

Metric ISO thread to DIN 13 - acc. to DIN 3852 part 1, form X and Y

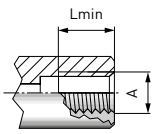

Part no.	Body size	Thread A (female thread)	Lmin*
TW17...-W9031-025	1	M10x1.0	7.0
TW17...-W9033-045	2	M12x1.0	9.5
TW17...-W9034-045	2	M12x1.5	9.5
TW17...-W9035-045	2	M14x1.5	9.5
TW17...-W9036-065	3	M16x1.5	10.5
TW17...-W9037-065	3	M18x1.5	10.5
TW17...-W9038-085	4	M20x1.5	10.5
TW17...-W9039-085	4	M22x1.5	10.5
TW17...-W9040-125	5	M24x1.5	11.0
TW17...-W9043-125	5	M26x1.5	11.0

\* Lmin: minimum thread length  
Other connection sizes on request

Metric ISO thread to DIN 13 - acc. to ISO 6149-1

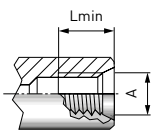

Part no.	Body size	Thread A (female thread)	Lmin*
TW17...-W9082-025	1	M10x1.0	7.0
TW17...-W9083-045	2	M12x1.5	9.5
TW17...-W9084-045	2	M14x1.5	9.5
TW17...-W9085-065	3	M16x1.5	10.5
TW17...-W9086-065	3	M18x1.5	10.5
TW17...-W9133-085	4	M20x1.5	10.5
TW17...-W9087-085	4	M22x1.5	10.5
TW17...-W9092-125	5	M27x2.0	11.0

\* Lmin: minimum thread length  
Other connection sizes on request

Ordering

Whitworth tube thread to DIN EN ISO 228-1 - acc. to DIN 3852 part 2, form X and Y

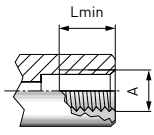

Part no.	Body size	Thread A (female thread)	Lmin*
TW17...-W9000-025	1	G1/8"	7.0
TW17...-W9001-045	2	G1/4"	9.5
TW17...-W9002-065	3	G3/8"	10.5
TW17...-W9003-085	4	G1/2"	10.5
TW17...-W9005-125	5	G3/4"	11.0
TW17...-W9006-165	6	G1"	12.5

\* Lmin: minimum thread length  
Other connection sizes on request

BSPT (tapered Whitworth tube thread) - acc. to DIN 3852 part 2, form X and Y

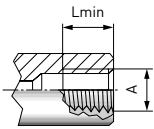

Part no.	Body size	Thread A (female thread)	Lmin*
TW17...-W9024-025	1	BSPT 1/8"	7.0
TW17...-W9025-045	2	BSPT 1/4"	9.5
TW17...-W9026-065	3	BSPT 3/8"	10.5
TW17...-W9027-085	4	BSPT 1/2"	10.5
TW17...-W9029-125	5	BSPT 3/4"	11.0
TW17...-W9030-165	6	BSPT 1"	12.5

\* Lmin: minimum thread length  
Other connection sizes on request

NPT thread (ANSI/ASME B1.20.1-1983) - acc. to SAE J476a

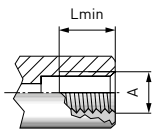

Part no.	Body size	Thread A (female thread)	Lmin*
TW17...-W9007-025	1	NPT 1/8"	7.0
TW17...-W9008-045	2	NPT 1/4"	9.5
TW17...-W9009-065	3	NPT 3/8"	10.5
TW17...-W9010-085	4	NPT 1/2"	10.5
TW17...-W9012-125	5	NPT 3/4"	11.0
TW17...-W9013-165	6	NPT 1"	12.5

\* Lmin: minimum thread length  
Other connection sizes on request

Ordering

SAE-O-Ring Boss - acc. to SAE J1926 / ISO 11926

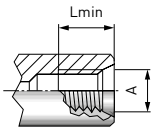

Part no.	Body size	Thread A (female thread)	Lmin*
<b>TW17...-W9047-025</b>	1	UNF 7/16"-20	7.0
<b>TW17...-W9048-045</b>	2	UNF 1/2"-20	9.5
<b>TW17...-W9049-045</b>	2	UNF 9/16"-18	9.5
<b>TW17...-W9052-065</b>	3	UNF 3/4"-16	10.5
<b>TW17...-W9053-085</b>	4	UNF 7/8"-14	10.5
<b>TW17...-W9055-125</b>	5	UN 1 1/16"-12	11.0
<b>TW17...-W9056-165</b>	6	UN 1 5/16"-12	11.0

\* Lmin: minimum thread length  
Other connection sizes on request

Other connection types on request.

Required information for ordering see page 7, catalog no. 35.

When ordering WEH® TW17 please indicate in addition to the details requested on page 7 in catalog no. 35 the following information:

**1. Part no.**

Please insert within the part no. the letter corresponding to the desired type of actuation (H, V or P) in place of the position indicator (...)

*Example: TW17H-W9031-025*

**2. Pressure range**

Please add LP = low pressure version (up to 50 bar) or HP = high pressure version (up to 350 bar) at the end of the part number.

*Example: TW17H-W9031-025/HP*

**ACCESSORIES**

The following accessories are available for the WEH® TW17 Quick connector:

**Screw plug for plug version**

If the WEH® Connector is used as a plug, the media inlet 'B1' can be sealed with a screw plug of stainless steel with an o-ring of NBR 70° Shore for high pressure range. It is recommended that the media compatibility of the seal be tested by the customer!



Part no.	Description	Connection (male thread)	Pressure range
<b>W9329</b>	Screw plug (high pressure)	G1/8"	0 - 350 bar
<b>W9330</b>	Screw plug (high pressure)	G1/4"	0 - 350 bar
<b>W9331</b>	Screw plug (high pressure)	G3/8"	0 - 350 bar
<b>W9332</b>	Screw plug (high pressure)	G1/2"	0 - 350 bar
<b>On request</b>	Screw plug (high pressure)	G3/4"	0 - 350 bar
<b>On request</b>	Screw plug (high pressure)	G1"	0 - 350 bar

**SPECIAL SOLUTIONS**

Examples:

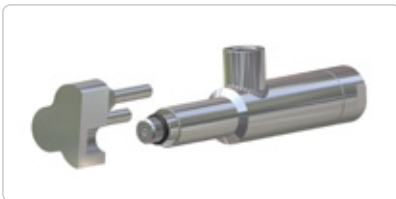

TW17P with extension



TW17V twin connector

## Technical explanations

### TECHNICAL EXPLANATIONS

#### Abbreviations/Definitions

For explanation of abbreviations and definitions of terms see applicable Technical Appendix of the corresponding catalog or [www.weh.com](http://www.weh.com)

#### Illustrations

The illustrations and/or images used in these data sheet are particularly provided for illustrative purposes only and may differ in some details from the actual product. For binding information, please refer to your individual orders.

#### Safe product selection

Our WEH® Products are designed to be operated by qualified professional users (insofar as WEH® Products are also designed to be operated by other users in individual cases, this is explicitly stated in the corresponding operating instructions). Please note that WEH does not know your system and therefore - also due to the large number of different potential applications of WEH® Products - cannot perform tests on all potential types of application. You alone are responsible for the selection, configuration and suitability of WEH® Products, especially according to the requirements of your system. Before purchasing WEH® Products, please particularly ensure that our products are compatible with your intended use, your performance data, your material and fluids, your system concept and your system limits according to our product specifications. Please also consider your technical and legal requirements for operation, handling and maintenance. The quality and safety of WEH® Products is our highest priority. For this reason, WEH® Products may not be used outside the specifications in the relevant data sheets and product descriptions. If you are not sure whether the WEH® Product is suitable for your system and intended use, please contact us in advance. We also strongly recommend that you refrain from using third-party spare parts or a combination of WEH® Products with unsuitable third-party products. You alone are responsible for reviewing the suitability of third-party products. WEH® Products and WEH® Spare parts comply with our quality and safety standards.

#### Service life

WEH® Products are generally products which may be subject to wear and fatigue during operation and depending on your individual application/use. For details - in particular regarding the corresponding minimum inspection and maintenance intervals - please refer to the respective operating instructions for the WEH® Product.

#### Explanation on the Pressure Equipment Directive

These WEH® Products are generally classified as pressure accessories in accordance with Article 2 (5) of the Pressure Equipment Directive 2014/68/EU and are considered to be similar to piping. These WEH® Products may not be used as safety accessories. Furthermore, it is pointed out, that these WEH® Products are designed and placed on the market in accordance with the requirements of Article 4 (3) of the Pressure Equipment Directive 2014/68/EU. The assessment with regard to a different classification can, however, be made on request.

#### External change management

WEH reserves the right to update, optimise and adjust its products continuously. This may result in corresponding changes of the product. Customers will be informed proactively or unsolicited by WEH only in individual cases about product updates, product optimisations and/or product adaptations that have been carried out. You are free to contact WEH at any time to request information about any product updates, product optimisations and/or product adjustments.

© All rights reserved, WEH GmbH Verbindungstechnik.

Any unauthorized copying, distribution or other use of the copyrighted content is strictly forbidden without the written consent of WEH GmbH Verbindungstechnik.

Upon transmission of a newer version of this document, all previous versions are no longer valid. In principle, the latest version of the document is valid. This can be found at [www.weh.com](http://www.weh.com).

Our General Terms and Conditions and the Agreement on Protection of Know-How and Quality Assurance ([www.weh.com](http://www.weh.com)) shall apply to deliveries and other services, unless expressly agreed otherwise.

We do not accept any General Terms and Conditions of the purchaser.

WEH® is a registered trademark of WEH GmbH Verbindungstechnik.

## » Contact

More questions? – Great! Don't hesitate to contact our experts.

Manufacturer:

**WEH GmbH Precision Connectors**

Josef-Henle-Str. 1  
89257 Illertissen / Germany

Phone: +49 7303 9609-0

E-Mail: [sales@weh.com](mailto:sales@weh.com)

Website: [www.weh.com](http://www.weh.com)